

APPLICATIONS

- Facilities maintenance
- Electricians
- Plumbers
- All maintenance and construction work
- Factory fit-outs in tight areas
- Ideal for warehouse use between racking and pipe work
- Aircraft maintenance – outdoor wind rated

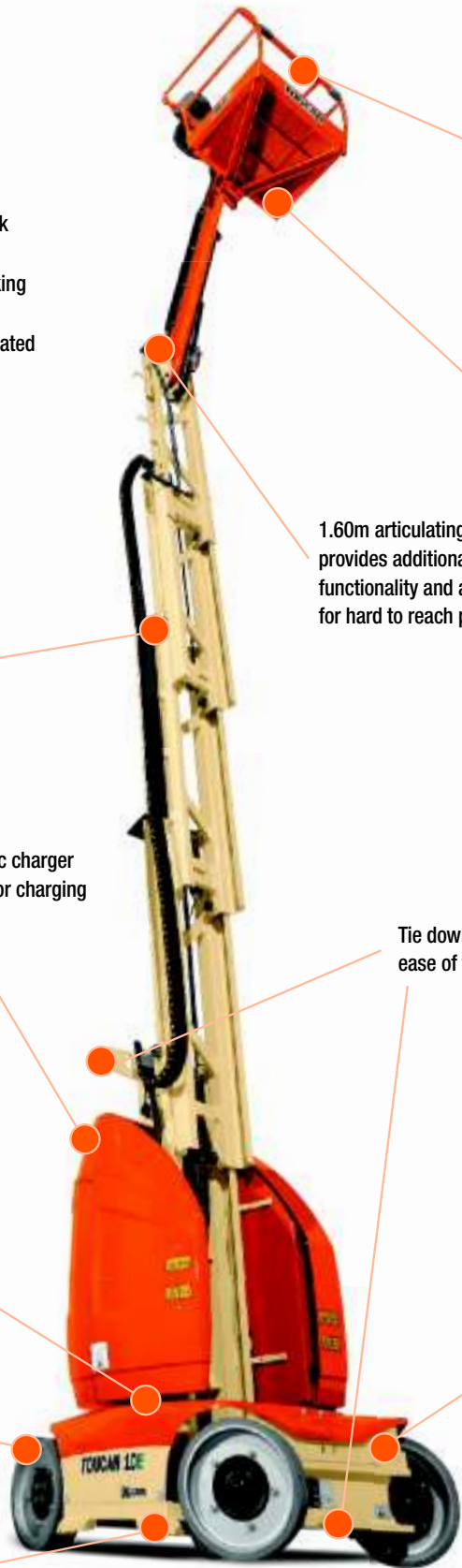

Fully proportional drive and slew joystick control with integral thumb-steer switch

Low maintenance steel platform with non-skid mesh floor, slide bar rear entry and Load Sensing System

1.60m articulating jib provides additional functionality and access for hard to reach places

See through telescopic mast provides fast operation from ground to full height, using main mast and jib. Incorporates a chain-slack detection system

Integrated automatic charger with 10 Amp inlet, for charging batteries overnight

Tie down and lifting lugs for ease of transport

Turntable slews mast-assembly through 345 degrees on heavy-duty slew bearings and gearbox. Allows slewing in tight areas when elevated

2 wheel direct electric drive with brushless AC drive motors and automatic rear wheel brakes

Non-marking tyres with solid cast steel rims

Passive pothole protection device

QUESTIONS TO ASK

- What are the ground conditions in the work area?
- What are the floor load requirements and access to the site?
- What is the working height needed for the job?
- What is the outreach required for the job?
- Is there 240V AC power available for charging?

KEY SELLING POINTS

- Smooth control, proportional 2 wheel drive with AC brushless motors
- Variable speed lift lower jib and swing controls, on the platform
- Vertical dual-chain lift mast with articulated jib boom
- Non-marking solid tyres
- 345 degree mast rotation and 1.60m articulating jib
- 2 degree tilt alarm with indicator light
- 24V DC traction battery for continued use
- Electronic, inverter-style battery charger
- Drive orientation system

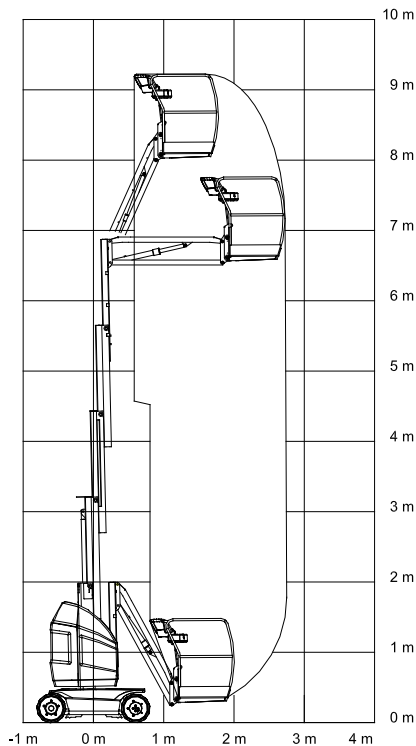

SPECIFICATIONS

Performance:

Platform Height (max.)	8.10m
Working Height	10.10m
Jib Raise Angle	+66°
Jib Lower Angle	-61°
Jib Articulation Range	127°
Maximum Horizontal Outreach	3.08m
Platform Capacity	200kg
Slewing Angle	345° Non-continuous

Dimensions:

Stowed Length	2.82m
Stowed Height	1.99m
Overall Width	0.99m
Wheelbase	1.20m
Ground Clearance	0.10m
Platform Width	0.90m
Platform Length	0.70m
Overall Jib Length	1.60m
Tailswing	0.13m

Power:

Power Source	Electric DC
DC Voltage	24V
Battery Traction	24V-240 Amp hr @ 5 hr rate

Travel:

Tyre Size	406 x 125
Tyre Type	Solid/Non-marking
Inside Turn Radius	0.55m
Outside Turn Radius	1.99m
Gradeability	25%
Drive Speed Lowered	5.50km/h
Drive Speed Elevated	0.75km/h
Drive Speed Full Elevation	0.40km/h
Maximum Ground Bearing Pressure	21kg/cm ²

Weights and Capabilities:

Hydraulic Tank Capacity	9.0 Ltr
GVW	2,990kg