



SJ6826/32 RT

ROUGH TERRAIN SCISSORS

STANDARD FEATURES

- Crossover symmetrical 4WD
- Drivable at full height with roll out deck fully extended
- Independent/auto leveling outriggers
- 1.52 m roll out extension deck
- Diesel engine
- 90° swing out engine tray
- Multiple wet disc SAHR brakes
- Wiring for AC outlet on platform
- Up to 50% gradeability (6826 RT)
- Tilt alarm with drive & lift cut-out
- All motion audible alarm
- Overload sensing system
- Lowering warning system
- Lanyard attachment points
- Operator horn
- Flashing lights
- Hinged railing system
- Forklift pockets and tie down/lift lugs
- Full height spring hinged gate at rear of unit
- Relay based control system
- Colour coded and numbered wiring system
- 26 x 12 low profile grip lug foam-filled tyres

ACCESSORIES AND OPTIONS

- Diesel scrubber
- Foam-filled non-marking tyres

* Capacities, and machine weights may differ when options are added

SJ6826/32 RT ROUGH TERRAIN SCISSORS

Dimensions	SJ6826 RT	SJ6832 RT
A Work Height	9.92 m	11.75 m
B Raised Platform Height	7.92 m	9.75 m
C Lowered Platform Height	1.23 m	1.37 m
D Overall Width	1.76 m	1.76 m
E Overall Length	3.35 m	3.35 m
F Stowed Height (Rails Up)	2.37 m	2.51 m
G Stowed Height (Rails Down)	1.61 m	1.75 m
H Platform Width (Inside Dimension)	1.42 m	1.42 m
I Platform Length (Inside Dimension)	2.44 m	2.44 m

Specifications	SJ6826 RT	SJ6832 RT
Extension Deck	1.52 m	1.52 m
Ground Clearance	0.20 m	0.20 m
Wheelbase	2.04 m	2.04 m
Weight	3,305 kg	3,655 kg
Gradeability	50%	40%
Turning Radius (Inside)	1.52 m	1.52 m
Turning Radius (Outside)	3.96 m	3.96 m
Lift Time (With Rated Load)	36 sec	39 sec
Drive Speed (Stowed)	6.1 km/h	6.1 km/h
Drive Speed (Raised)	0.6 km/h	0.6 km/h
Maximum Drive Height	Full Height	Full Height
Capacity (Overall)	567 kg	454 kg
Maximum # of Persons (0 wind rating)	4	4
Maximum # of Persons (12.5 m/sec wind rating)	4	2

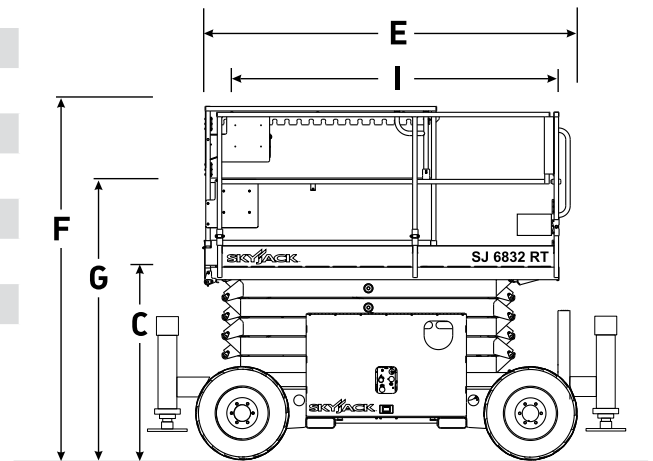
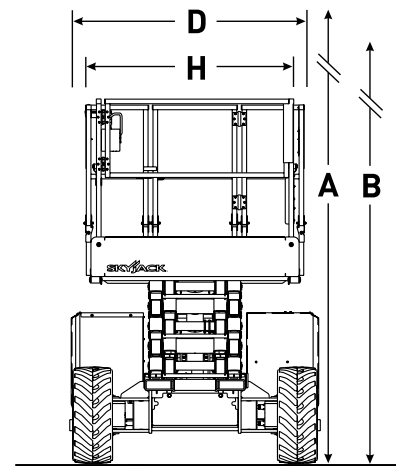

Skyjack Australia Pty Ltd
 4 Coates Place
 Wetherill Park
 New South Wales, 2164
 Tel: +61 (0) 2878 63200
 Fax: +61 (0) 2878 63222
 Email: jcranmer@skyjack.com

www.skyjack.com

This brochure is for illustrative purpose only and based on the latest information at the time of printing. Skyjack Inc. reserves the right to make changes at any time, without notice, to specifications, standard and optional equipment. Consult the Operating Maintenance and Parts Manuals for proper procedures. AS marked platforms are in conformance to Standard AS/NZS 1418.10:2011.