



Excellent maneuverability in the most congested areas:

- ☑ proportional controls provide smooth and progressive movements
- ☑ zero turning radius
- ☑ vertical tilting allowing better accessibility to the work area 3m outreach

Optimal productivity :

- ☑ Driveable at full height
- ☑ no machine height means longer working cycles

Robust, reliable, easy to maintain

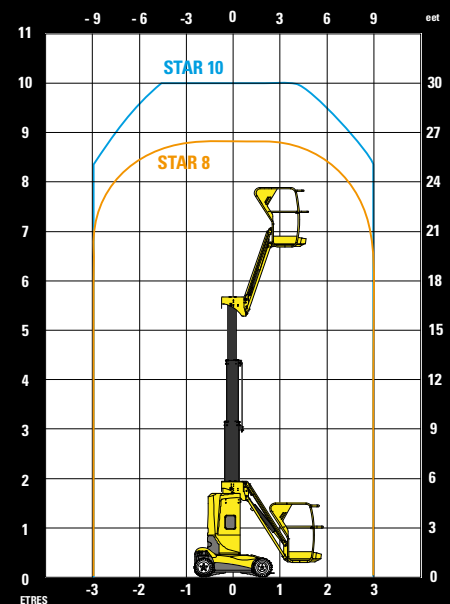

STAR 8 / STAR 10

ERT CA ASTS

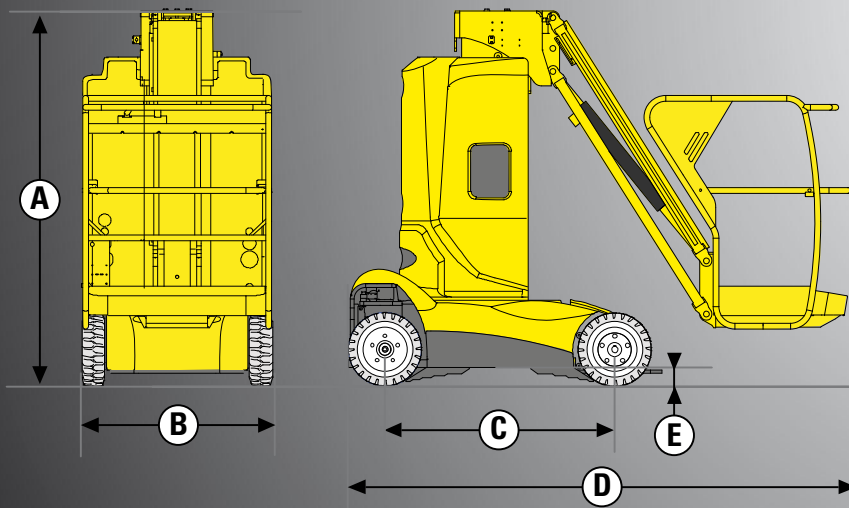

TEC CA DATA

STAR 8 STAR 10

Working Height	8,2 m	10 m
Platform height	6 2 m	8 m
Horizontal outreach	3 m	3 m
Platform capacity	200 kg	200 kg
Platform size	0,7 x 0,99 m	0,7 x 0,99 m
D - length	2 65 m	2 65 m
B - Width	1 m	1 m
A - height - stored	1 99 m	1 99 m
Tailswing	0 cm	0 cm
C - heelbase	1 2 m	1 2 m
E - Ground Clearance	10 cm	10 cm
Driveable at full height up to	6 2 m	8 m
Drive speed proportional	0,7 - 4,5 km/h	0,7 - 4,5 km/h
Turning radius - outside	1 88 m	1 88 m
Turntable rotation	345°	345°
Vertical rotation	140 70/-60	130 70/-60
Tires - non marking	16x5x10,5	16x5x10,5
Tilt alarm	3	3
Gradeability	23 %	23 %
Hydraulic system capacity	7 l	7 l
Power source	24 V - 240 Amph	24 V - 240 Amph
Weight	2595 kg	2760 kg

STANDARD EQUIPMENT

- 24 Electric motor
- 24 240 Ah traction batteries
- 30 Amp battery charger
- Battery charge indicator
- Fixed potholes
- 2 drive speed
- 2 front steering wheels
- 2 back driving wheels
- Non-marking tires
- Brake release
- Hourmeter
- Horn
- Emergency stop buttons at cage and ground level
- Load controller in the platform
- Emergency hand pump
- 2 control stations at cage and ground level
- Fixed control station in the platform
- 2 rings in the platform for safety harnesses
- Tooling hooks and lifting eyes

OPTIONAL ACCESSORIES

- Power line in platform
- Maintenance-free batteries
- Centralised battery filling
- Travel alarm
- Flashing light
- Working light
- Air line in platform
- Cold weather package
- Biodegradable oil



Haulotte GROUP